

NISSAN
FORKLIFT

Platinum G04 Series

Heavyweight Pneumatic Tire

8,000 lb. - 11,000 lb.
Capacities



Platinum G04 series

Dimensions

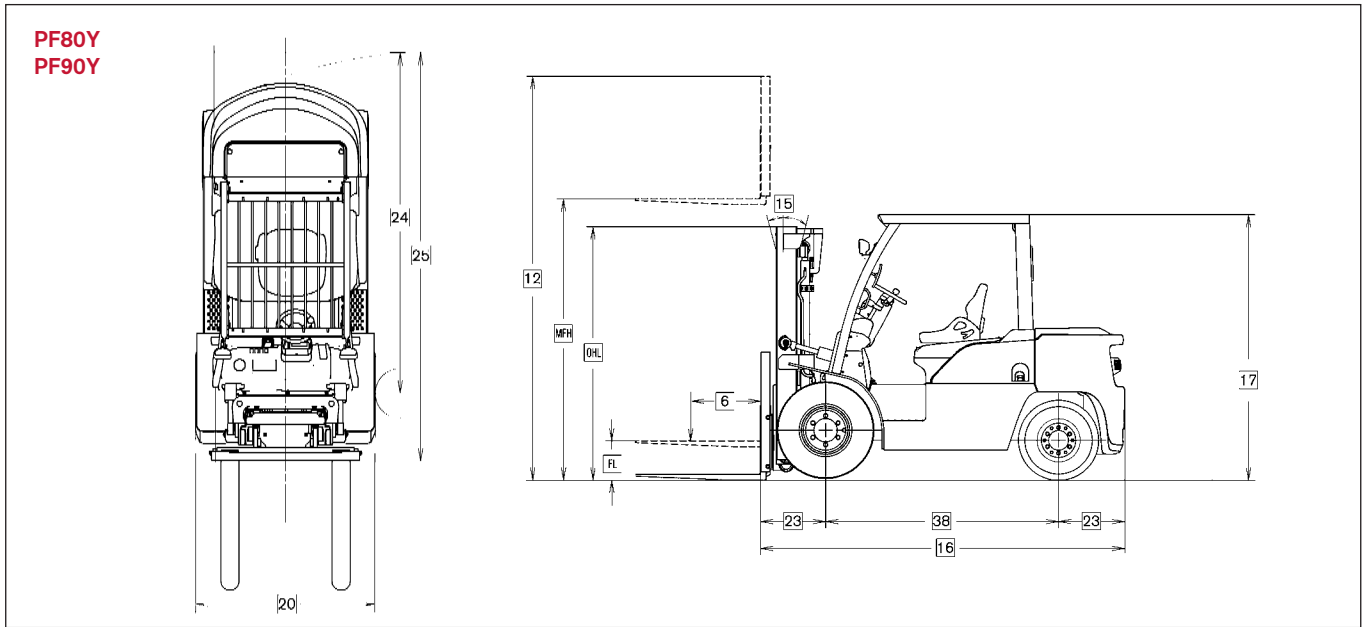

Mast Specifications & Rated Capacities

Mast Type	Mast Name	Max. Fork Height	Overall Height				Free Lift		Tilt Angle	Rated Capacity at 24" Load Center				
			Lowered		Fully Extended		FL			PF80Y		PF90Y		
			MFH	OHL	With LBR	Without LBR	With LBR	Without LBR		Fwd/ Bkwd	Single Drive	Dual Drive	Single Drive	Dual Drive
			in	in	in	in	in	in		deg	lb.	lb.	lb.	lb.
TWO STAGE (Wide view)	2W300	118	84.4	169.3	151.0	5.1	5.1	6/12	8000	8000	9000	9000		
	2W330	130	90.4	181.1	162.8	5.1	5.1	6/12	8000	8000	9000	9000		
	2W350	138	95.7	189.0	170.7	5.1	5.1	6/12	8000	8000	9000	9000		
	2W370	146	100.2	196.9	178.5	5.1	5.1	6/12	8000	8000	9000	9000		
	2W400	157	108.1	208.7	190.4	5.1	5.1	6/12	8000	8000	9000	9000		
	2W450	177	117.9	228.3	210.0	5.1	5.1	6/6	8000	8000	9000	9000		
	2W500	197	127.8	248.0	229.7	5.1	5.1	6/6	8000	8000	9000	9000		
THREE STAGE (Full free)	3F385	152	78.5	202.8	186.0	29.5	46.3	6/6	8000	8000	9000	9000		
	3F430	169	84.4	220.5	203.7	35.4	52.2	6/6	8000	8000	9000	9000		
	3F475	187	90.4	238.2	221.5	41.3	58.1	6/6	8000	8000	9000	9000		
	3F515	203	95.7	253.9	237.2	46.7	63.4	6/6	7800	8000	8700	8700		
	3F550	217	100.2	267.7	251.0	51.2	67.9	6/6	5300	7600	6900	8500		
	3F600	236	108.1	287.4	270.7	59.1	75.8	6/6	4000	7200	5200	8300		

8,000 / 9,000 lb. capacities

Main Truck Specifications

				Nissan Forklift	Nissan Forklift	Nissan Forklift	Nissan Forklift		
CHARACTERISTICS	1	Manufacturer's Name			Nissan Forklift	Nissan Forklift	Nissan Forklift	Nissan Forklift	1
	2	Model	Model designation	1 spd (2 spd)	PF80Y(H)LP / DF	PFD80Y(H)	PF90Y(H)LP / DF	PFD90Y(H)	2
	3		Long model code	1 spd (2 spd)	MJ1F4A(F)35LV / DV	MW1F4A(F)35V	MJ1F4A(F)40LV / DV	MW1F4A(F)40V	3
	4	Power Type			LP - G/LP	Diesel	LP - G/LP	Diesel	4
	5	Rated Load Capacity		lb (kg)	8000 (3625)		9000 (4080)		5
	6	Load Center	Distance	in (mm)	24 (600)		24 (600)		6
	7	Operator Orientation			Sit		Sit		7
DIMENSIONS	8	Tire Type	Front & rear		Pneumatic		Pneumatic		8
	9	Wheels	Number - front/rear (x=driven)		2x / 2		2x / 2		9
	10	Mast	Maximum fork height	in (mm)	130 (3300)		130 (3300)		10
	11		Mast lowered (OHL)	in (mm)	90.4 (2295)		90.4 (2295)		11
	12		Mast extended with LBR	in (mm)	181.1 (4600)		181.1 (4600)		12
	13		Standard freelif	in (mm)	5.1 (130)		5.1 (130)		13
	14	Forks	Length x thickness x width	in (mm)	48 x 2 x 6 (1220 x 50 x 150)		48 x 2 x 6 (1220 x 50 x 150)		14
	15	Tilt Angle	Standard mast - fwd/back	degree	6 / 12		6 / 12		15
	16	Overall Dimensions	Length (to face of forks)	in (mm)	121.8 (3095)		123.1 (3130)		16
	17		Height - top of OHG	in (mm)	92.5 (2350)		92.5 (2350)		17
	18		Height - top of standard LBR	in (mm)	48.0 (1220)		48.0 (1220)		18
	19		Width - standard carriage	in (mm)	47.2 (1200)		47.2 (1200)		19
	20	Overall Width	Width - single tire / single wide tire	in (mm)	58.7 (1490) / 58.7 (1490)		— / 58.7 (1490)		20
	21		Width - dual tire / dual wide tire	in (mm)	69.9 (1775) / 77.6 (1190)		69.9 (1775) / 77.6 (1190)		21
22	Grade Clearance Angle	Departure	%	40		38		22	
23	Overhang	Front / rear	in (mm)	22.0 (560) / 21.1 (535)		22.0 (560) / 22.4 (568)		23	
24	Turning Radius	Minimum outside	in (mm)	107.1 (2720)		108.3 (2755)		24	
25	Min Right Angle Stack	Add load length & clearance	in (mm)	129.1 (3280)		130.3 (3315)		25	
PERFORMANCE	26	Travel Speed Forward	1st speed - loaded / unloaded	mph (km/h)	11.2 (18) / 11.2(18)	11.2 (18) / 12.1(19.5)	11.2 (18) / 11.2(18)	11.2 (18) / 12.1 (19.5)	26
	27	Maximum	2nd speed - loaded / unloaded	mph (km/h)	13.7 (22) / 13.7 (22)	14.6 (23.5) / 15.2 (24.5)	13.7 (22) / 13.7 (22)	14.6 (23.5) / 15.2 (24.5)	27
	28	Lifting/Lowering Speed	Lift - loaded / unloaded	fpm (mm/sec)	94.5 (480) / 94.5 (480)	98.4 (500) / 102.4 (520)	94.5(480) / 94.5 (480)	98.4(500) / 102.4 (520)	28
	29	Maximum	Lowering - loaded / unloaded	fpm (mm/sec)	98.4(500) / 98.4 (500)	98.4 (500) / 98.4 (500)	98.4 (500) / 98.4 (500)	98.4 (500) / 98.4 (500)	29
	30	Drawbar Pull Maximum	Full load - at 1 mph	lb (N)	6865 (30500)	6600 (29350)	7065 (31400)	6800 (30200)	30
	31		No load - at 1 mph	lb (N)	5875 (26100)	5225 (23220)	6070 (27000)	5420 (24070)	31
	32	Gradeability Maximum	Full load / no load - at 1 mph	%	32 / 27	27 / 27	28 / 26	26 / 24	32
WEIGHT	33	Truck Weight	No load - standard truck	lb (kg)	12890 (5840)	12780 (5790)	13390 (6065)	13280 (6015)	33
	34	Weight Distribution	Front axle - empty	lb (kg)	5685 (2575)	5740 (2600)	5630 (2550)	5685 (2575)	34
	35		Rear axle - empty	lb (kg)	7210 (3265)	7040 (3190)	7760 (3515)	7595 (3440)	35
	36		Front axle - with rated load	lb (kg)	17890 (8105)	17945 (8130)	19580 (8870)	19635 (8895)	36
	37		Rear axle - with rated load	lb (kg)	2725 (1235)	2560 (1160)	2635 (1195)	2490 (1120)	37
CHASSIS & WHEELS	38	Wheelbase		in (mm)	78.5 (2000)		78.5 (2000)		38
	39	Tire Size	Front Tread - single / single wide		8.25 x 15-14PR / 300 x 15-18PR		— / 300 x 15-18PR		39
	40		Front Tread - dual / dual wide		7.50 x 16-12PR / 8.25 x 15-12PR		7.50 x 16-12PR / 8.25 x 15-12PR		40
	41		Rear Tread		7.00 x 12-12PR		7.00 x 12-12PR		41
	42	Tread - Center of Tire	Front Tread - single / single wide	in (mm)	49.2 (1250) / 46.5 (1180)		— / 46.5 (1180)		42
	43		Front Tread - dual/dual wide	in (mm)	51.5 (1310) / 56.9 (1445)		51.5 (1310) / 56.9 (1445)		43
	44		Rear Tread	in (mm)	46.5 (1180)		46.5 (1180)		44
	45	Seat Height		in (mm)	46.0 (1170)		46.0 (1170)		45
	46	Headroom	SIP to bottom of OHG	in (mm)	45.1 (1145)		45.1 (1145)		46
	47	Counterweight Height		in (mm)	50.2 (1275)		50.2 (1275)		47
	48	Step Height		in (mm)	18.7 (475)		18.7 (475)		48
	49	Floor Height		in (mm)	31.3 (795)		31.3 (795)		49
50	Ground Clearance	Under mast / power unit / frame	in (mm)	5.7 (145) / 6.7 (170) / 8.9 (225)		5.7 (145) / 6.7 (170) / 8.9 (225)		50	
DRIVE LINE	51	Service Brake	Type		Foot, Hydraulic Boost		Foot, Hydraulic Boost		51
	52	Parking Brake	Type		Hand, Mechanical		Hand, Mechanical		52
	53	Steering	Type		Hydrostatic, Power		Hydrostatic, Power		53
	54	Engine	Model		Nissan TB45	TD42	Nissan TB45	TD42	54
	55	Rated Output	SAE gross - LP, Diesel	hp (kW) @ rpm	95.6 (71.3) @ 2450	86 (64.1) @ 2400	95.6 (71.3) @ 2450	86 (64.1) @ 2400	55
	56	Rated Torque	SAE gross - LP, Diesel	ft-lb (Nm) @ rpm	209.4 (284) @ 1600	188 (254.6) @ 2400	209.4 (284) @ 1600	188 (254.6) @ 2400	56
	57	Displacement		cu in (cm ³)	273 (4478)	254 (4169)	273 (4478)	254 (4169)	57
	58	Transmission	Type & Speeds - 1 speed		Powershift, 1 fwd / 1 rev		Powershift, 1 fwd / 1 rev		58
	59		Type & Speeds - 2 speed		Automatic, 2 fwd / 1 rev		Automatic, 2 fwd / 1 rev		59

Platinum G04 series

Dimensions

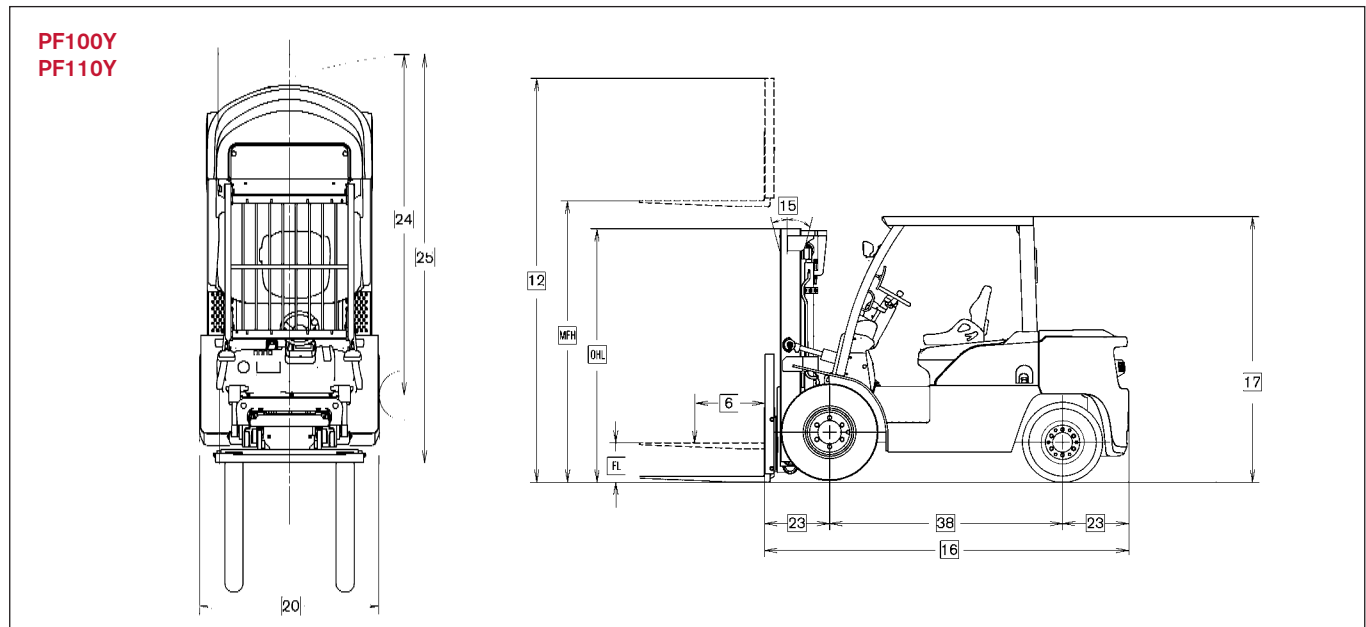

Mast Specifications & Rated Capacities

Mast Type	Mast Name	Max. Fork Height	Overall Height		Free Lift		Tilt Angle	Rated Capacity at 24" Load Center				
			Lowered	Fully Extended	FL			PF100Y		PF110Y		
			MFH	OHL	With LBR	Without LBR*	With LBR	Without LBR	Fwd/Bkwd	Single Drive	Dual Drive	Single Drive
		in	in	in	in	in	in	deg	lb.	lb.	lb.	lb.
TWO STAGE (Wide view)	2W300	118	84.4	169.3	153.0	6.9	6.9	6/12	10000	10000	11000	11000
	2W330	130	90.4	181.1	164.8	6.9	6.9	6/12	10000	10000	11000	11000
	2W350	138	95.7	189.0	172.6	6.9	6.9	6/12	10000	10000	11000	11000
	2W370	146	100.2	196.9	180.5	6.9	6.9	6/12	10000	10000	11000	11000
	2W400	157	108.1	208.7	192.3	6.9	6.9	6/12	10000	10000	11000	11000
	2W450	177	117.9	228.3	212.0	6.9	6.9	6/6	10000	10000	11000	11000
	2W500	197	127.8	248.0	231.7	6.9	6.9	6/6	10000	10000	11000	11000
THREE STAGE (Full free)	3F385	152	84.4	202.8	186.4	35.6	52.0	6/6	10000	10000	11000	11000
	3F430	169	90.4	220.5	204.1	41.5	57.9	6/6	10000	10000	11000	11000
	3F475	187	95.7	238.2	221.9	46.9	63.2	6/6	10000	10000	11000	11000
	3F515	203	100.2	253.9	237.6	51.4	67.7	6/6	9600	10000	9800	11000
	3F550	217	108.1	267.7	251.4	59.3	75.6	6/6	7000	9700	7100	10800
	3F600	236	117.9	287.4	271.1	69.1	85.4	6/6	5300	9400	5400	9600

* Overall Height - Fully Extended Without LBR, should be reduced by 1.2" to calculate PF100Y Two-Stage Masts (2W)

10,000 / 11,000 lb. capacities

Main Truck Specifications

				Nissan Forklift	Nissan Forklift	Nissan Forklift	Nissan Forklift		
CHARACTERISTICS	1	Manufacturer's Name			Nissan Forklift	Nissan Forklift	Nissan Forklift	Nissan Forklift	1
	2	Model	Model designation	1 spd (2 spd)	PF100Y(H)LP/DF	PFD100Y(H)	PF110Y(H)LP/DF	PFD110Y(H)	2
	3		Long model code	1 spd (2 spd)	MJ1F4A(F)45LV/DV	MW1F4A(F)45V	MJ1F4A(F)50LV/DV	MW1F4A(F)50V	3
	4	Power Type			LP - G/LP	Diesel	LP - G/LP	Diesel	4
	5	Rated Load Capacity		lb (kg)	10000 (4535)		11000 (4990)		5
	6	Load Center	Distance	in (mm)	24 (600)		24 (600)		6
	7	Operator Orientation			Sit		Sit		7
DIMENSIONS	8	Tire Type	Front & rear		Pneumatic		Pneumatic		8
	9	Wheels	Number - front/rear (x=driven)		2x / 2		2x / 2		9
	10	Mast	Maximum fork height	in (mm)	130 (3300)		130 (3300)		10
	11		Mast lowered (OHL)	in (mm)	90.4 (2295)		90.4 (2295)		11
	12		Mast extended with LBR	in (mm)	181.1 (4600)		181.1 (4600)		12
	13		Standard freelif	in (mm)	6.9 (175)		6.9 (175)		13
	14	Forks	Length x thickness x width	in (mm)	48 x 2 x 6 (1220 x 50 x 150)		48 x 2 x 6 (1220 x 50 x 150)		14
	15	Tilt Angle	Standard mast - fwd/back	degree	6 / 12		6 / 12		15
	16	Overall Dimensions	Length (to face of forks)	in (mm)	126.3 (3210)		131.5 (3340)		16
	17		Height - top of OHG	in (mm)	92.5 (2350)		92.5 (2350)		17
	18		Height - top of standard LBR	in (mm)	48.0 (1220)		48.0 (1220)		18
	19		Width - standard carriage	in (mm)	47.2 (1200)		47.2 (1200)		19
	20	Overall Width	Width - single wide tire	in (mm)	58.7 (1490)		58.7 (1490)		20
	21		Width - dual tire / dual wide tire	in (mm)	69.9 (1775) / 77.6 (1190)		69.9 (1775) / 77.6 (1190)		21
	22	Grade Clearance Angle	Departure	%	36		36		22
23	Overhang	Front / rear	in (mm)	23.1 (587) / 24.5 (622)		23.5 (597) / 23.3 (593)		23	
24	Turning Radius	Minimum outside	in (mm)	110.2 (2800)		115.6 (2940)		24	
25	Min Right Angle Stack	Add load length & clearance	in (mm)	133.3 (3387)		139.1 (3537)		25	
PERFORMANCE	26	Travel Speed Forward	1st speed - loaded / unloaded	mph (km/h)	11.2 (18) / 11.2 (18)	11.2 (18) / 12.1 (19.5)	11.2 (18) / 11.2 (18)	11.2 (18) / 12.1 (19.5)	26
	27	Maximum	2nd speed - loaded / unloaded	mph (km/h)	13.7 (22) / 13.7 (22)	14.6 (23.5) / 15.2 (24.5)	13.7 (22) / 13.7 (22)	14.6 (23.5) / 15.2 (24.5)	27
	28	Lifting/Lowering Speed	Lift - loaded / unloaded	fpm (mm/sec)	82.7 (420) / 82.7 (420)	84.6 (430) / 88.6 (450)	82.7 (420) / 82.7 (420)	82.7 (420) / 86.6 (440)	28
	29	Maximum	Lowering - loaded / unloaded	fpm (mm/sec)	88.6 (450) / 88.6 (450)	88.6 (450) / 88.6 (450)	88.6 (450) / 88.6 (450)	88.6 (450) / 88.6 (450)	29
	30	Drawbar Pull Maximum	Full load - at 1 mph	lb (N)	7260 (32300)	6990 (31050)	7470 (33200)	7175 (31900)	30
	31		No load - at 1 mph	lb (N)	6280 (27900)	5610 (24920)	6480 (28800)	5795 (25770)	31
	32	Gradeability Maximum	Full load / no load - at 1 mph	%	25 / 24	24 / 22	23 / 22	22 / 20	32
WEIGHT	33	Truck Weight	No load - standard truck	lb (kg)	15185 (6880)	15090 (6835)	16300 (7385)	16290 (7380)	33
	34	Weight Distribution	Front axle - empty	lb (kg)	6115 (2770)	6180 (2800)	6745 (3055)	6745 (3055)	34
	35		Rear axle - empty	lb (kg)	9070 (4110)	8910 (4035)	9560 (4330)	9545 (4325)	35
	36		Front axle - with rated load	lb (kg)	21940 (9940)	22010 (9970)	23920 (10835)	23930 (10840)	36
	37		Rear axle - with rated load	lb (kg)	3180 (1440)	3015 (1365)	3420 (1550)	3400 (1540)	37
CHASSIS & WHEELS	38	Wheelbase		in (mm)	78.5 (2000)		84.5 (2150)		38
	39	Tire Size	Front Tread - single wide		300 x 15-18PR		300 x 15-18PR		39
	40		Front Tread - dual / dual wide		7.50 x 16-12PR / 8.25 x 15-12PR		7.50 x 16-12PR / 8.25 x 15-12PR		40
	41		Rear Tread		7.00 x 12-16PR		7.00 x 12-16PR		41
	42	Tread - Center of Tire	Front Tread - single wide	in (mm)	46.5 (1180)		46.5 (1180)		42
	43		Front Tread - dual / dual wide	in (mm)	51.5 (1310) / 56.9 (1445)		51.5 (1310) / 56.9 (1445)		43
	44		Rear Tread	in (mm)	46.5 (1180)		46.5 (1180)		44
	45	Seat Height		in (mm)	46.0 (1170)		46.0 (1170)		45
	46	Headroom	SIP to bottom of OHG	in (mm)	45.1 (1145)		45.1 (1145)		46
	47	Counterweight Height		in (mm)	50.2 (1275)		50.2 (1275)		47
	48	Step Height		in (mm)	18.7 (475)		18.7 (475)		48
	49	Floor Height		in (mm)	31.3 (795)		31.3 (795)		49
50	Ground Clearance	Under mast / power unit / frame	in (mm)	5.7 (145) / 6.7 (170) / 8.9 (225)		5.7 (145) / 6.7 (170) / 8.9 (225)		50	
DRIVE LINE	51	Service Brake	Type		Foot, Hydraulic Boost		Foot, Hydraulic Boost		51
	52	Parking Brake	Type		Hand, Mechanical		Hand, Mechanical		52
	53	Steering	Type		Hydrostatic, Power		Hydrostatic, Power		53
	54	Engine	Model		Nissan TB45	TD42	Nissan TB45	TD42	54
	55	Rated Output	SAE gross - LP, Diesel	hp (kW) @ rpm	95.6 (71.3) @ 2450	86 (64.1) @ 2400	95.6 (71.3) @ 2450	86 (64.1) @ 2400	55
	56	Rated Torque	SAE gross - LP, Diesel	ft-lb(Nm)@rpm	209.4(284)@1600	188 (254.6)@2400	209.4(284)@1600	188(254.6)@2400	56
	57	Displacement		cu in (cm ³)	273 (4478)	254 (4169)	273 (4478)	254 (4169)	57
	58	Transmission	Type & Speeds - 1 speed		Powershift, 1 fwd / 1 rev		Powershift, 1 fwd / 1 rev		58
	59		Type & Speeds - 2 speed		Automatic, 2 fwd / 1 rev		Automatic, 2 fwd / 1 rev		59

Platinum G04 Series

Technical Information

Standard Equipment

1. Nissan's own TB45, LP or dual fuel, in-line, 6-cylinder industrial engine
2. Low emission, EPA Diesel Tier III, TD42, in-line, 6-cylinder industrial diesel engine, with an electronic controlled Quick Glow System for dependable cold weather starting
3. Computer controlled Electronic Concentrated Control System (ECCS)¹, electronic fuel injection technology, with single-port fuel injection (LP) / multi-port injection (Gas), providing low emission levels, well below EPA Tier II and CARB requirements
4. Engine/transmission protection and warning system to safeguard your investment¹
5. Single speed powershift transmission with full floating powertrain
6. Multi-function LCD display with operator PIN security access
7. On-board diagnostics and programmable service reminder
8. Hydrostatic power steering
9. Hydraulic boosted brakes
10. Seat actuated Operator Presence System includes power interrupt, auto-mast lock, return-to-neutral, audio and visual warnings
11. Full suspension seat with operator restraint system
12. Seat belt warning system, horn, and back-up alarm
13. Tilt-adjustable steering wheel
14. Engine coolant temperature gauge and low fuel warning light (LP) / fuel gauge (Gas/Diesel)
15. Speedometer and F/N/R transmission indicator
16. Hour meter, clock, and calendar
17. Single lift/tilt hydraulic control lever
18. High air intake system with large 7" cyclone air filter
19. Swing-down LP bracket (LP and dual fuel models only)¹

20. Overhead guard mounted headlights
21. 5-piece reinforced overhead guard
22. Cushioned floor mat

Optional Equipment

1. Travel speed control (high/low speed settings) and Power/Economy controlled acceleration mode¹
2. Dual fuel engine for LP and Gasoline
3. UL safety rating available for LP fuel type
4. Two speed automatic transmission
5. Separate lift & tilt hydraulic control levers
6. Synchronized steering with spinner knob
7. Swivel seat with rear OHG mounted assist grip with horn button
8. Solid or dual drive pneumatic tires
9. Anti-Dust, Low Noise, or Corrosion Resistant packages
10. Tilt cylinder boots or covers
11. Vertical exhaust
12. Radiator screen
13. Air intake pre-cleaner
14. Rear combination light package
15. Rotating beacon or strobe light
16. Rear work light
17. Low overhead guard (88.5")

Operator Comfort and Control

A spacious operator compartment provides generous foot, leg and head room for a variety of driver sizes. A standard full suspension, fold down seat with soft touch arm pads and hip restraints provides maximum operator comfort and enhanced safety. Its low profile design offers ample head clearance, while front to back travel adjustment allows a comfortable, customized fit for nearly any operator height.

The Platinum G04's, tilt-adjustable steering wheel helps the operator quickly find his or her ideal driving position, while its compact design offers enhanced control and handling.

Hydrostatic power steering minimizes steer effort and operator fatigue. Hydraulic boosted brakes offer reduced pedal effort and improved brake durability. An optional swivel seat produces greater operator comfort and visibility while driving in reverse, and includes a rear assist grip with horn button to further enhance operator productivity. Automotive-style light and turn signal levers simplify repetitive actions allowing the operator to focus on the job. An optional auto tilt leveling system assists proper mast/fork positioning.

Enhanced comfort results from the Platinum G04 Series' Operator Comfort System, which includes a full suspension seat, cushion floor mat, pedals mounted to the chassis frame, and rubber shock absorbers located throughout the vehicle to reduce vibration from the engine and transmission to the operator. For additional vibration reduction, Platinum G04 Series includes an automotive-type floating powertrain design, which incorporates four rubber engine/transmission supports. The G04's chassis has been designed with a low center of gravity (CG), with the roll center of the rear axle mounted close to the CG, for enhanced stability.

The G04 features tandem hydraulic pumps, with one pump for lifting and one pump for the power steering and brake booster. A priority load sensing control valve allows the steering/brake pump to supply hydraulic oil to the lift system when not required for steering/braking.

Enhanced Work Environment

Several standard features are included in the Platinum G04 Series to deliver a more comfortable and productive work environment for the operator and those in the surrounding area.

The Nissan engines offer extremely low noise levels at the operator's ear during idle and at maximum travel speeds. For the TB45 engine, an optional travel speed control feature is available to control high or low maximum travel speed settings, while the optional controlled acceleration's economy mode adjusts throttle

sensitivity to increase fuel efficiency, extend drivetrain life and reduce excessive tire wear. The two-speed models feature an automatic transmission with reduced shift shock due to shortened shift time lag and utilization of an optimized shift schedule.

The Platinum G04's Operator Presence System, with seat-actuated power interrupt, incorporates a mast-lock which automatically locks lift and tilt operations when the operator leaves the seat, and a return to neutral feature to minimize forklift movement if the operator leaves the seat while the lift truck is still in gear. This presence system also includes audible and visual warnings if either the seat belt is not engaged, or when the parking brake has not been applied prior to the operator exiting the compartment.

For easy entry/exit from either side, welded metal assist grips, combined with a replaceable metal traction plate bolted to the truck's wide, low entry step, provide the operator with sure, comfortable footing and grip for this often repeated task. Our own swing-down LP bracket design uses a gas spring assist to reduce operator effort during tank replacement.

Durable Design Features

The G04 Series is built for toughness, with a robust mast, strong frame, thick steel fenders, and 5-ton truck drive and steer axles on all models.

The G04's superior cooling system consists of an oversized fan and wide cooling outlet, for enhanced airflow, and a heavy-duty radiator, with transmission oil cooler, rubber mounted to reduce flexing and absorb vibration for enhanced reliability. Its improved cooling capacity translates into dependable cooling efficiency under heavy usage or high ambient temperatures.

A heavy-duty steer axle, cast for improved axle strength, protects the steer cylinder from damage, while steer cylinder boot covers keep out dirt and debris. The rear axle ball joints, with dust covers for protection against dirt, include grease fittings for easy lubrication to provide longer life and steering ease.

Technical Information Platinum G04 Series

Technical Information

Lift cylinders include oil return piping for reduced heat generation and extended life. The counterweight is designed to deflect cooling airflow down and away from the truck, and it features a built-in radiator protection bar.

IP55 & IP65 rated control modules, combined with a wiring harness with sealed connectors, provides protection against dirt and corrosion.

Ease of Maintenance

Tilt cylinders can be greased without removing any body panels. One bolt removal allows the two-piece floorboard to be lifted off, promoting simple access to hydraulic components. Detachable side panels and a wide-open clamshell hood provide a roomy area for service technicians to perform their tasks. The five-piece reinforced overhead guard simplifies replacement of individual components if necessary, saving time and money. A window in the floor board allows for quick and easy brake fluid checks.

A multi-function LCD display includes

on-board diagnostics to keep service time low, with a programmable service reminder in order to stay current with periodic maintenance needs. Its display design provides the operator with excellent visibility and understanding of warning indicators.

Electronic Fuel Injection Engine Technology

Platinum G04 Series' LP and Dual Fuel models are powered by Nissan's own TB45 (4.5 liter) electronic fuel injected industrial engine. Its Electronic Concentrated Control System (ECCS) analyzes engine performance parameters and optimizes engine operation, resulting in enhanced productivity and lower fuel consumption. This system includes three main components: Engine Control Module (ECM), Vehicle Control Module (VCM), and Multi-function LCD Display.

The ECM responds to sensor input to control basic engine related functions, such as proper air/fuel ratio, torque and speed, based on the requirements of the application. The

VCM monitors a number of sensors to alert the operator of changing conditions via a full range of warning indicators located on the truck's LCD display. All communication among these components occurs through a Controller Area Network (CAN) system.

The TB45 industrial engine is specifically designed and tested for industrial applications in order to deliver the power and torque to meet the needs of the application. As an added safeguard for your investment, the Platinum G04's TB45 engine includes an engine/transmission protection and warning system to reduce engine rpm in the event of excessive heat generation or loss of oil pressure.

Low Emission Engines LP/Dual Fuel

Nissan Forklift's global commitment to preserving and protecting the environment is evident in the Platinum G04 Series' ECCS engine, providing exceptionally low emission levels that are well below EPA Tier II and CARB

requirements. Nissan Forklift is the first lift truck manufacturer to receive EPA and CARB certification for their own line-up of industrial engines, setting us apart as the world leader in clean air engine technology. The TB45's combination of ECCS, automotive-type closed-loop design, and three-way catalytic converter provides enhanced fuel economy and lower exhaust emissions.

Diesel

The TD42 diesel industrial engine offers improved fuel consumption and near elimination of particulate matter, with emission levels well below EPA Tier III requirements. A completely new, electronically regulated, Quick Glow System results in considerably reduced glow times, providing faster engine starting in cold weather.

¹Available on LP and dual fuel models only.

Optional Equipment



Wide, dual or solid pneumatic tire options available.



Rear work light, or rear strobe light, for enhanced awareness.



Brake lights, turn signals, and backup lights or large size rearview mirrors.



Air intake pre-cleaner for extended filter life.



Polycarbonate rain guard, with water diversion channels, partially opaque for protection from the sun.



Tilt cylinder boots or tilt cylinder covers for protection against dirt and dust. Mast tilt gauge provides visual indication for vertical alignment of mast.

Option Availability

Platinum G04 Series Pneumatic Models

Standard S Option O

		Fuel Types		
		LP	Dual Fuel	Diesel
Vehicle Management	Vehicle Control Module (VCM)	S	S	S
	Multi-function LCD Meter Panel display	S	S	S
	Security PIN access	S	S	S
	On-board diagnostics and service reminder	S	S	S
	Engine coolant temperature gauge	S	S	S
	Oil pressure, transmission fluid and coolant temperature warning indicator	S	S	S
	Low LP fuel warning indicator	S	S	-
	Fuel gauge (Gas, Diesel)	-	S	S
	Low coolant warning ¹	S	S	S
	Air cleaner warning	S	S	S
Powertrain	Engine Control Module (ECM)	S	S	-
	Engine/transmission protection system	S	S	-
	Floating powertrain for reduced vibration	S	S	S
	Three-way catalytic converter	S	S	-
	Travel speed control - high/low speed selector	O	O	-
	Controlled acceleration - power/economy modes	O	O	-
	Radiator screen	O	O	O
	UL Safety rating	O	-	-
Operator Presence System	Seat actuated auto-mast lock system	S	S	S
	Automatic return-to-neutral	S	S	S
	Seatbelt warning	S	S	S
Steering System	Tilt steering wheel	S	S	S
	Hydrostatic power steering system	S	S	S
Brake	Parking brake with warning buzzer	S	S	S
	Hydraulic boosted brakes	S	S	S
Hydraulic System	Single lift/tilt control lever	S	S	S
	Separate lift & tilt control levers	O	O	O
	Auto-tilt leveling system	O	O	O
	Hydraulic load sensing valve system	S	S	S
Operator Conveniences	Full suspension seat	S	S	S
	OHG-mounted headlights	S	S	S
	Swing-down LP bracket	S	S	-
	Cushioned floor mat	S	S	S
	Back-up alarm	S	S	S
	Rearview mirrors	O	O	O
	Rear combination lights with front turn signals	O	O	O
	Rear work light	O	O	O
	Strobe light or rotating beacon	O	O	O

1. Not available on LPS models



SS-G04 12-12
Printed in U.S.A.

www.nissanforklift.com



NISSAN
GREEN PROGRAM



Scan for more information

Nissan Forklift, Platinum, OPTIVIEW, Nomad, and the Nissan Forklift logo are all registered trademarks of Nissan Forklift Corporation, North America. Nissan Forklift Corporation reserves the right to make product changes relating to colors, equipment, specifications or available options without notice. For more information, contact your Nissan Forklift representative.

NISSAN
FORKLIFT

