

ELECTRIC POWERED CUSHION TIRE TRUCKS

Yale® ERC-VA electric trucks are available in 3,000 – 4,000 pound capacities designed for demanding applications that require clean, quiet-running, heavy-duty capability. These trucks are extremely maneuverable and offer plenty of power and high stacking ability, while also offering excellent ergonomics, reliability and maintenance ease.

AC TRANSISTOR TRACTION CONTROL

AC technology offers smooth acceleration and directional changes, as well as proportional regenerative braking. The controller converts battery power to three phase AC power, and adjusts frequency and current to meet performance demands. Performance control settings and extensive diagnostics are accessible by technicians through the dash display or a PC. A Vehicle Systems Manager utilizing CANbus technology monitors and controls key truck components and systems. The advanced thermal management system monitors component temperature and gradually adjusts performance to prevent damage to key components.

CONTROLLER AREA NETWORK (CANBUS)

CANbus technology streamlines communications between truck systems through one main master controller, the Vehicle System Manager (VSM). LCD display, traction controller and pump controller are all controlled via the CANbus network. A connection point is provided for interface with a service PC.

Intellix VSM acts as a master truck controller, providing extensive monitoring and control of truck functions and systems. CANbus technology reduces wiring complexity and enables comprehensive communications between truck systems. The ergonomically positioned display transmits continual feedback to the operator and allows for communication of service codes.

ELECTRICAL SYSTEM

The ERC-VA utilizes AC motor technology designed for exceptional performance. It uses a brushless induction motor for high starting torque and smooth rapid acceleration. A speed sensor provides feedback to the control system, allowing motor speed and direction to be continuously monitored.

POWER ASSISTED BRAKING

Power Assisted Braking is accomplished via the VSM. The VSM monitors brake line pressure. When this pressure exceeds a set threshold the VSM sends a signal to the traction controller to decelerate the traction motor proportionally to the brake pressure. The higher the brake pedal pressure being applied, the more quickly the truck will decelerate. Duo-servo hydraulic brakes are self-adjusting and self-energizing for reduced pedal effort. The master cylinder is sealed and has an external fluid level sensor connected to a warning indicator on the display. A foot applied/hand-released parking brake is manually adjustable and has an audible warning if the

operator leaves the truck without applying the brake. The standard Auto Deceleration System automatically slows the truck when the operator's foot is removed from the accelerator pedal, extending brake life.

VOLTAGE

36 and 48 volt systems are available to meet a variety of application requirements. A solid-state, return-to-neutral feature reduces the possibility of inadvertent truck movement.

OPERATOR INTERFACE DISPLAY

The repositioned display is conveniently located in the upper right area of the operator's compartment. The display includes an hour meter, LCD display for status codes and descriptions, battery discharge indicator with lift interrupt, warning indicator for brake fluid, performance mode indicator, and parking brake indicator. The display also permits access for service technicians to adjust performance control settings, allowing the truck to be customized to meet customer applications. Additionally, extensive diagnostics allow service technicians to quickly troubleshoot problems. Operator selectable performance modes are standard. Options for operator passwords and a pre-shift operator checklist are also available.

FOOT DIRECTIONAL CONTROL PEDAL (FDC) (OPTIONAL)

The foot directional control pedal is a highly productive directional/accelerator pedal. One pedal allows the operator to change direction and acceleration reducing operator movement and resulting in increased productivity.

HYDRAULIC COMPONENTS

A transistor control hydraulic system is powered by a brushless, AC induction motor for long life and low noise. The motor and pump are

(continued on back)



Truck shown with optional equipment.

BATTERY AND COMPARTMENT SPECIFICATIONS														
Trucks with UL Type "E" Construction														
Battery Compartment Dimensions				Battery Dimensions and Specifications										
Compartment Type	Width	Length	Height	"X"		"Y"		"Z"	Volts	No. of Cells	Plates per Cell	Max Capacity 6 Hour Rate	Weight	
				Min	Max	Min	Max	Max					Min	Max
	in (mm)			in (mm)								amp hr (kwh)	lb (kg)	
Vertical Removal (Lift Out)	35.8 (909)	27.6 (700)	24 (610)	30.9 (784)	35.7 (907)	25.7 (654)	27.2 (692)	23.5 (598)	36	18	17 - 19	1200 (40.6)	1850 (839)	2500 (1132)
									48	24	13 - 15	1000 (45.2)		
Horizontal Removal with Battery Rollers	35.8 (909)	27.6 (700)	23.5 (597)	30.9 (784)	35.7 (907)	25.7 (654)	27.2 (692)	23 (585)	36	18	17 - 19	1200 (40.6)	1850 (839)	2500 (1132)
									48	24	13 - 15	1000 (45.2)		

BATTERY AND COMPARTMENT SPECIFICATIONS														
Trucks with UL Type "EE" Construction														
Battery Compartment Dimensions				Battery Dimensions and Specifications										
Compartment Type	Width	Length	Height	"X"		"Y"		"Z"	Volts	No. of Cells	Plates per Cell	Max Capacity 6 Hour Rate	Weight	
				Min	Max	Min	Max	Max					Min	Max
	in (mm)			in (mm)								amp hr (kwh)	lb (kg)	
Vertical Removal (Lift Out)	35.6 (904)	27.6 (700)	24 (610)	30.9 (784)	35.5 (902)	25.7 (654)	27.2 (692)	23.5 (598)	36	18	17 - 19	1200 (40.6)	1850 (839)	2500 (1132)
									48	24	13 - 15	1000 (45.2)		
Horizontal Removal with Battery Rollers	35.6 (904)	27.6 (700)	23.5 (597)	30.9 (784)	35.5 (902)	25.7 (654)	27.2 (692)	23 (585)	36	18	17 - 19	1200 (40.6)	1850 (839)	2500 (1132)
									48	24	13 - 15	1000 (45.2)		

Battery Type: "EO" (Without Cover)

Battery amp hr (kwh) capacity is max allowable per UL

Commercially available lead acid batteries may not necessarily reach these max limits

Battery Compartment Length is measured front to rear. Battery Compartment Width is measured across the truck

Battery Notes – Conventional Charging (Opt G26201)

Battery Connector: 36 volt - Gray SB®350 (Anderson Power Products® P/N 6320G1 or equivalent)

48 volt - Blue SB®350 (Anderson Power Products® P/N 6321G1 or equivalent)

Battery Lead: Length 20" (508mm), Position "B", 2/0 AWG

Battery Notes – Rapid/Fast Charging (Opt G26202)

Battery Connector: Requires Dual Positive/Negative Cabling terminating in (2) Female EBC-320 DIN Connectors

(Anderson Power Products® P/N A32502-0009 or equivalent)

Each individual DIN connector to include 1 Red Conductor to (+) and 1 Black Conductor to (-)

Battery Lead: Length 25" (635mm), Position "B", Minimum Cable Size 3/0 AWG

ERC30-40VA MAST DIMENSIONS					
Maximum Fork Height (TOF) +	Overall Lowered Ht.	Overall Extended Height w/Load Backrest	Overall Extended Height w/o Load Backrest	Free-Lift (TOF) w/ Load Backrest	Free-Lift (TOF) w/o Load Backrest
in. (mm)	in. (mm)	in. (mm)	in. (mm)	in. (mm)	in. (mm)
2-STAGE LIMITED FREE-LIFT (LFL) MAST					
127 (3232)	82 (2080)	176 (4455)	150 (3806)	5 (140)	5 (140)
2-STAGE FULL FREE-LIFT (FFL) MAST					
126 (3218)	82 (2080)	176 (4461)	151 (3812)	31 (807)	57 (1456)
138 (3518)	88 (2230)	188 (4761)	162 (4112)	37 (957)	63 (1606)
3-STAGE FULL FREE-LIFT (FFL) MAST					
181 (4600)	80 (2030)	224 (5025)	204 (5174)	29 (757)	55 (1406)
187 (4750)	82 (2080)	236 (5325)	210 (5324)	31 (807)	57 (1455)
192 (4900)	84 (2130)	238 (5375)	216 (5474)	33 (857)	59 (1506)
198 (5050)	88 (2230)	248 (5625)	222 (5624)	37 (957)	63 (1606)
216 (5500)	94 (2380)	265 (6075)	240 (6074)	43 (1107)	69 (1756)

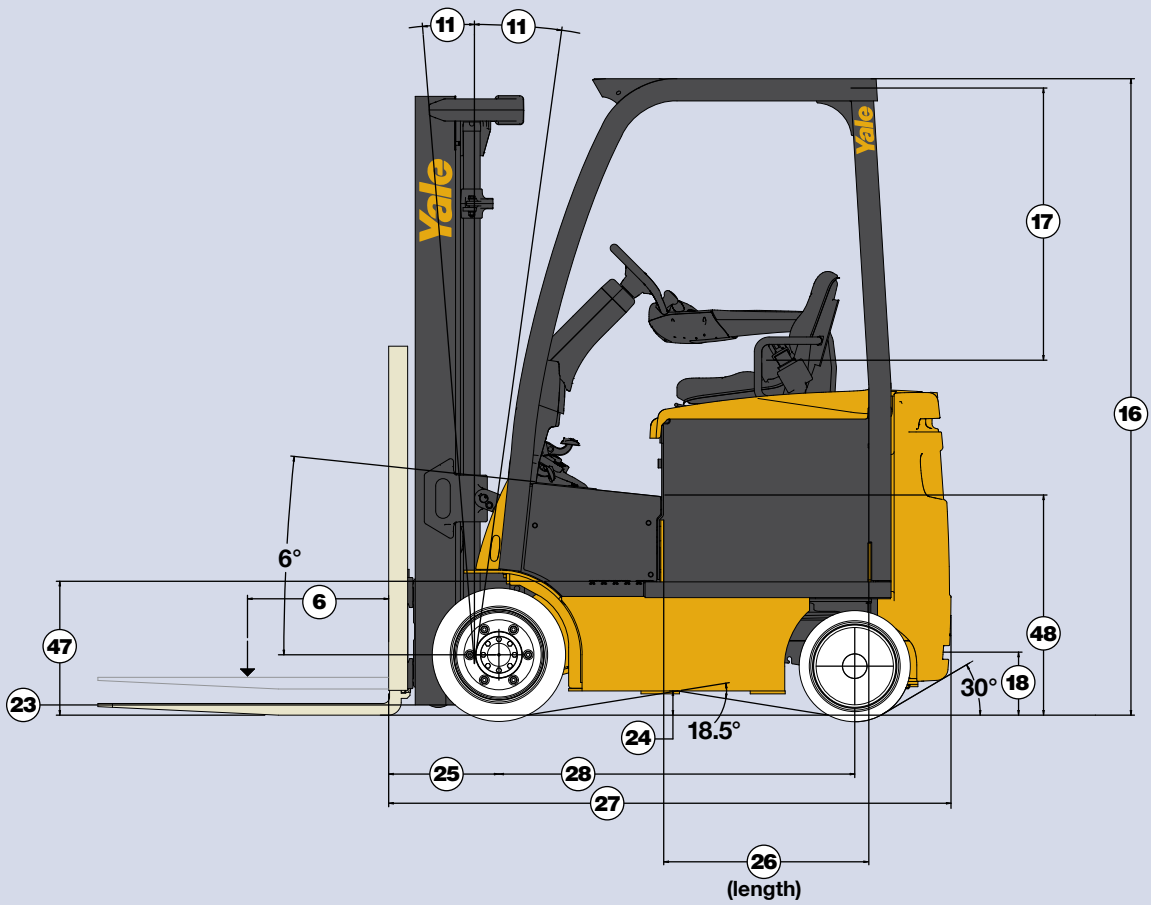
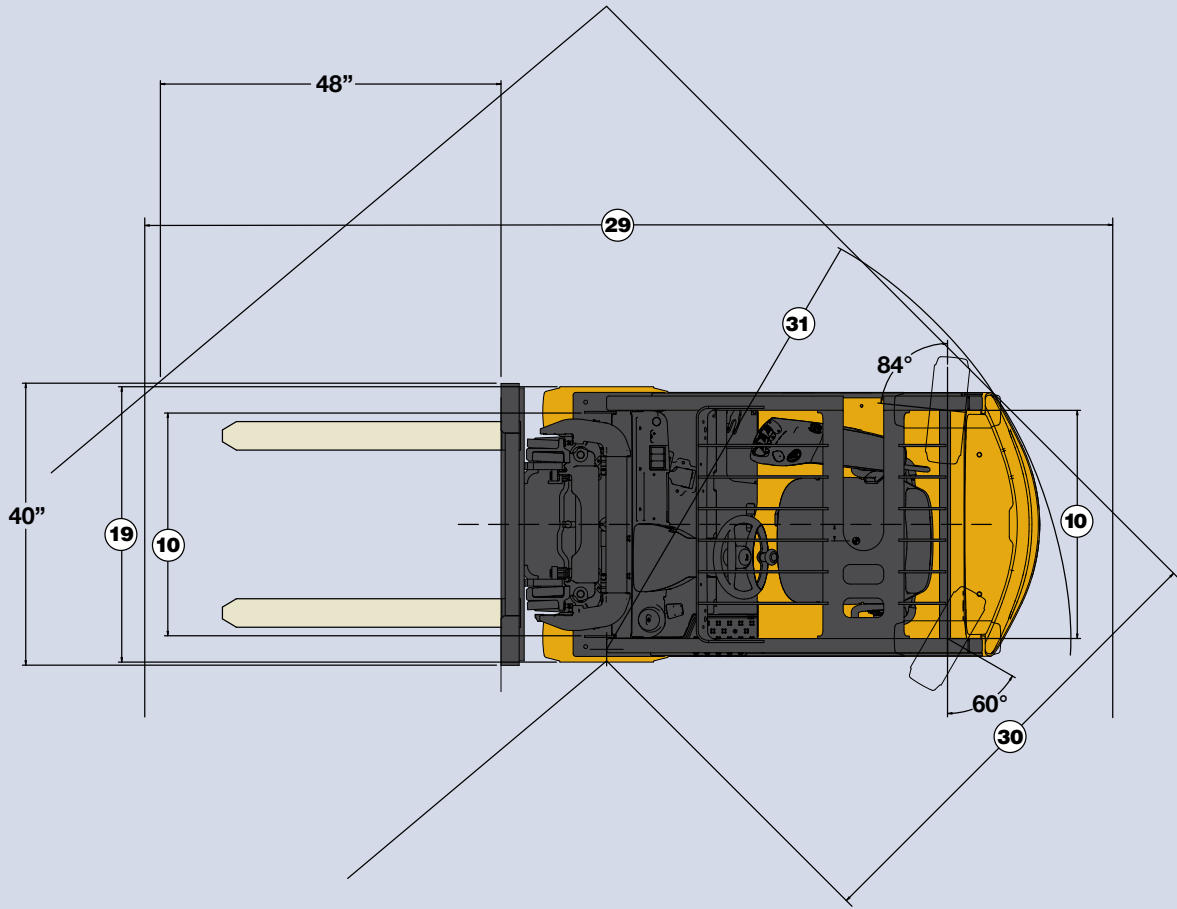

GENERAL	1	Manufacturer				Yale®	
	2	Model Designation				ERC030VA	
	3	Power				Electric	
	4	Operation				Sit	
	5	Rated Capacity			lb. (kg)	3000 (1361)	
	6	Load Center			in. (mm)	24 (610)	
TIRES	7	Tire Type - Cushion, Solid, Pneumatic, etc.		Drive / Steer		Cushion / Cushion	
	8	Tire Size	Std	Drive / Steer	in.	18 x 6 x 12.1 / 14 x 4.5 x 8	
			Opt	Drive / Steer	in.	18 x 7 x 12.1 / 15 x 5 x 11.25	
	9	Wheels - Number	X=Driven	Drive / Steer		2X / 2	
10	Tread - Drive	Center of Tires	Nar / Int / Wide 6" / Wide 7"	in. (mm)	31 / 31.8 / 37 / 35.7 (788 / 808 / 939 / 906)		
	Tread - Steer	Center of Tires		in. (mm)	32.4 (822)		
DIMENSIONS	11	Mast Tilt	Std Opt		degrees	5F / 5B 10F / 5B	
	12	Mast - Lowered Height	Std Mast		in. (mm)	82 (2080)	
	13	Free Lift - Top of Fork	Std 2 Stg Limited Free Lift Mast		in. (mm)	5 (140)	
			Opt 2 Stg Full Free Lift Mast with / without LBR		in. (mm)	31 / 57 (807 / 1456)	
	14	Lift Height - Top of Fork	Std 2 Stg Limited Free Lift Mast		in. (mm)	127 (3232)	
	15	Mast - Extended Height	Std Mast with / without LBR		in. (mm)	176 / 150 (4455 / 3806)	
	16	Overhead Guard Height	Std & DIR / Opt Grid / Flat Plate		in. (mm)	88.5 / 86.5 / 83.5 (2248 / 2197 / 2121)	
	17	SIP to Underside OHG	Depressed / Std OHG	Std / Full Susp	in. (mm)	38.7 / 38.9 (984 / 989)	
	18	Tow Pin Height	Vertical Center of Pin		in. (mm)	9.1 (232)	
	19	Overall Width	Nar / Int / Wide 6" / Wide 7" Tread		in. (mm)	37.2 / 38.8 / 43 / 42.7 (945 / 986 / 1091 / 1084)	
	20	Forks	Thickness x Width x Length		in. (mm)	1.6 x 3.9 x 42 (40 x 100 x 1067)	
	21	Standard Carriage Width	Class II		in. (mm)	35.7 (907)	
	22	Floor to Top of Battery Rollers			in. (mm)	17.1 (435)	
	23	Ground Clearance	Lowest Point	NL / RL	in. (mm)	3.5 / 3.3 (90 / 84)	
	24	Ground Clearance	Center of Truck	NL / RL	in. (mm)	3.9 / 3.6 (98 / 92)	
	25	Load Distance	Center of Wheel to Face of Forks		in. (mm)	14.2 (360)	
	26	Battery Compartment	Height	Std / Battery Rollers	in. (mm)	24 / 23.5 (610 / 597)	
			Width	UL Classification "E" / "EE"	in. (mm)	35.8 / 35.6 (909 / 904)	
			Length		in. (mm)	27.6 (700)	
	27	Length to Face of Forks	Chassis Length		in. (mm)	75.1 (1908)	
	28	Wheelbase			in. (mm)	48 (1220)	
29	Right Angle Stack			in. (mm)	127 (3226)		
30	Equal Aisle	90° Intersecting Aisle		in. (mm)	68.7 (1745)		
31	Outside Turning Radius			in. (mm)	64.7 (1644)		
WT.	32	Truck Weight	Without Battery	NL	lb. (kg)	5130 (2327)	
	33	Axle Loading - Drive	Static with Max. Wt. Battery	NL / RL	lb. (kg)	3460 / 8840 (1569 / 4010)	
	34	Axle Loading - Steer	Static with Max. Wt. Battery	NL / RL	lb. (kg)	4170 / 1790 (1891 / 812)	
PERFORMANCE	35	Travel Speed	Extended Shift OFF	NL / RL	mph (km/h)	11.4 / 11.4 (18.4 / 18.4)	48
			Extended Shift ON	NL / RL	mph (km/h)	11.4 / 11.4 (18.4 / 18.4)	11.4 / 11.4 (18.4 / 17.9)
	36	Lift Speed	Std 2 Stg LFL Mast	NL / RL	ft/min (m/sec)	126 / 83 (0.64 / 0.424)	142 / 93 (0.72 / 0.47)
			Opt 2 Stg FFL Mast	NL / RL	ft/min (m/sec)	113 / 75 (0.573 / 0.38)	127 / 83 (0.645 / 0.421)
			Opt 3 Stg FFL Mast	NL / RL	ft/min (m/sec)	117 / 77 (0.594 / 0.393)	131 / 86 (0.668 / 0.436)
	37	Lower Speed	Std 2 Stg LFL Mast	NL / RL	ft/min (m/sec)	93 / 100 (0.47 / 0.51)	
			Opt 2 Stg FFL Mast	NL / RL	ft/min (m/sec)	73 / 91 (0.37 / 0.46)	
			Opt 3 Stg FFL Mast	NL / RL	ft/min (m/sec)	81 / 94 (0.41 / 0.48)	
	38	Gradability	5 Minute Rating	NL / RL	%	31.1 / 23.7	
			60 Minute Rating	NL / RL	%	7 / 5.4	
39	Drawbar Pull	5 Minute Rating	NL / RL	lbf (N)	2734 / 2856 (12163 / 12705)		
		60 Minute Rating	NL / RL	lbf (N)	630 / 694 (2804 / 3087)		
40	Brake	Method of Control	Service / Parking		Hydraulic / Mechanical		
		Method of Operation	Service / Parking		Foot / Foot (Optional Park Brake – Automatic)		
ELECTRIC	41	Battery	Type		Lead Acid		
	42	Traction Motor	60 Minute Rating		hp (kW)	24.7 (18.4)	
	43	Pump Motor	S3-15%		hp (kW)	21.5 (16)	
	44	Traction Motor	Type / Control Method		AC / Transistor		
	45	Pump Motor	Type / Control Method		AC / Transistor		
	46	Number of Speeds	Traction / Pump		Infinitely Variable / Infinitely Variable		
OTHER	47	Step Height			in. (mm)	18.7 (475)	
	48	Floor Height	Lowest Point		in. (mm)	30.4 (772)	
	49	Attachment Relief Pressure	Mech Levers / Mini Levers		psi (bar)	2596 / 2596 (179 / 179)	
	50	Auxiliary Oil Flow	3rd Function / 4th Function		gal/min (l/min)	10.6 / 10.6 (40 / 40)	
	51	Sound Level	Measured per ANSI B56.11.5		dB (A)	64	

Above specifications, unless otherwise listed, are for a standard truck without optional equipment.

Right Angle Stack and Equal Intersecting Aisle dimensions provided with a 48" long and 40" wide pallet load, allowing zero clearance

Yale®		Yale®		1	GENERAL
ERC035VA		ERC040VA		2	
Electric		Electric		3	
Sit		Sit		4	
3500 (1588)		4000 (1814)		5	
24 (610)		24 (610)		6	
Cushion / Cushion		Cushion / Cushion		7	TIRES
18 x 6 x 12.1 / 14 x 4.5 x 8		18 x 7 x 12.1 / 15 x 5 x 11.25		8	
18 x 7 x 12.1 / 15 x 5 x 11.25		N / A / N / A		9	
2X / 2		2X / 2		10	
31 / 31.8 / 37 / 35.7 (788 / 808 / 939 / 906)		N/A / 31.8 / N/A / 35.7 (N/A / 808 / N/A / 906)		11	
32.4 (822)		32.4 (822)		12	
5F / 5B 10F / 5B		5F / 5B 10F / 5B		13	
82 (2080)		82 (2080)		14	
5 (140)		5 (140)		15	
31 / 57 (807 / 1456)		31 / 57 (807 / 1456)		16	
127 (3232)		127 (3232)		17	
176 / 150 (4455 / 3806)		176 / 150 (4455 / 3806)		18	
88.5 / 86.5 / 83.5 (2248 / 2197 / 2121)		88.5 / 86.5 / 83.5 (2248 / 2197 / 2121)		19	
38.7 / 38.9 (984 / 989)		38.7 / 38.9 (984 / 989)		20	
9.1 (232)		9.1 (232)		21	
37.2 / 38.8 / 43 / 42.7 (945 / 986 / 1091 / 1084)		38.8 / 42.7 (986 / 1084)		22	
1.6 x 3.9 x 42 (40 x 100 x 1067)		1.6 x 3.9 x 42 (40 x 100 x 1067)		23	
35.7 (907)		35.7 (907)		24	
17.1 (435)		17.1 (435)		25	
3.5 / 3.3 (90 / 84)		3.5 / 3.3 (90 / 84)		26	
3.9 / 3.6 (98 / 92)		3.9 / 3.6 (98 / 92)		27	
14.2 (360)		14.2 (360)		28	
24 / 23.5 (610 / 597)		24 / 23.5 (610 / 597)		29	
35.8 / 35.6 (909 / 904)		35.8 / 35.6 (909 / 904)		30	
27.6 (700)		27.6 (700)		31	
75.9 (1929)		77.5 (1968)		32	
48 (1220)		48 (1220)		33	
127.8 (3247)		128.7 (3270)		34	
68.8 (1748)		69.1 (1754)		35	
65.2 (1657)		66.6 (1692)		36	
5390 (2445)		5770 (2617)		37	
3400 / 9680 (1542 / 4391)		3340 / 10510 (1515 / 4767)		38	
4490 / 1710 (2037 / 776)		4830 / 1760 (2191 / 798)		39	
36	48	36	48	40	
11.4 / 11.4 (18.4 / 18.4)	11.4 / 11.4 (18.4 / 18.4)	11.4 / 10.5 (18.4 / 16.9)	11.4 / 11.4 (18.4 / 18.4)	41	
11.4 / 10.7 (18.4 / 17.3)	11.4 / 11.4 (18.4 / 18.4)	11.4 / 9.5 (18.4 / 15.3)	11.4 / 11.1 (18.4 / 17.9)	42	
126 / 77 (0.64 / 0.392)	142 / 96 (0.72 / 0.49)	126 / 74 (0.64 / 0.376)	142 / 93 (0.72 / 0.47)	43	
113 / 69 (0.573 / 0.351)	127 / 86 (0.645 / 0.439)	113 / 66 (0.573 / 0.337)	127 / 83 (0.645 / 0.421)	44	
117 / 72 (0.594 / 0.364)	131 / 90 (0.668 / 0.455)	117 / 69 (0.594 / 0.349)	131 / 86 (0.668 / 0.436)	45	
93 / 100 (0.47 / 0.51)		93 / 100 (0.47 / 0.51)		46	
73 / 91 (0.37 / 0.46)		73 / 91 (0.37 / 0.46)		47	
81 / 94 (0.41 / 0.48)		81 / 94 (0.41 / 0.48)		48	
30.8 / 23	33.8 / 23.5	30.4 / 22.7	33.6 / 23.2	49	
7 / 5.2	7.4 / 5.6	7 / 5	7.4 / 5.4	50	
2681 / 2800 (11924 / 12455)	2738 / 2857 (12178 / 12709)	2621 / 2744 (11658 / 12205)	2681 / 2801 (11924 / 12459)	51	
618 / 680 (2748 / 3026)	630 / 694 (2804 / 3088)	605 / 667 (2693 / 2965)	617 / 680 (2745 / 3023)	52	
Hydraulic / Mechanical		Hydraulic / Mechanical		53	
Foot / Foot (Optional Park Brake – Automatic)		Foot / Foot (Optional Park Brake – Automatic)		54	
Lead Acid		Lead Acid		55	
24.7 (18.4)	24.7 (18.4)	24.7 (18.4)	24.7 (18.4)	56	
21.5 (16)	21.5 (16)	21.5 (16)	21.5 (16)	57	
AC / Transistor		AC / Transistor		58	
AC / Transistor		AC / Transistor		59	
Infinitely Variable / Infinitely Variable		Infinitely Variable / Infinitely Variable		60	
18.7 (475)		18.7 (475)		61	
30.4 (772)		30.4 (772)		62	
2596 / 2596 (179 / 179)		2596 / 2596 (179 / 179)		63	
10.6 / 10.6 (40 / 40)		10.6 / 10.6 (40 / 40)		64	
64		64		65	

(continued from page 1)

mounted on rubber isolators for reduced noise and vibration. A combination of flexible wire-braid hoses and steel tubing is used to simplify the hydraulic plumbing. These hydraulic lines are carefully routed and held in place to reduce possible damage. A 10-Micron full flow hydraulic filter located in the return line protects the hydraulic system from contaminants and helps provide long life. A by-pass relief valve permits oil flow in the event of the filter clogging.

HYDROSTATIC POWER STEERING

Hydrostatic power steering is standard and the all-hydraulic design gives precise, reliable control while eliminating mechanical linkages and road shocks at the steering wheel. An infinitely adjustable tilt steering column provides excellent operator comfort and visibility.

STEERING AXLE

The steering axle is a one-piece ductile iron casting mounted on elastic cushions that reduce shock and provide a softer ride. The Continuous Stability System enhances truck stability in a simple, maintenance free design, without compromising uneven surface travel.

MASTS/CARRIAGE/FORKS/LOAD BACKREST EXTENSION

Yale® 2-stage Limited Free Lift (LFL) and 2 or 3 stage Full Free Lift (FFL) masts provide excellent visibility. The mast features flush face design with geometrically matched, angled load rollers, which are canted, yet provide full-face roller contact. A single free lift chain provides increased visibility. The mast front rail flange angle coupled with the inverted “J” inner channel and three degree mast rollers significantly reduces channel web milling and roller wear. Top accessible, “J-hook” mast mounting system allows convenient mast installation and removal. The J-hook mounting is standardized to allow direct mast interchangeability on a variety of Yale truck models without modification. Bronze steel backed bushings reduce mounting wear. Class II six-roller carriages are standard. Forks are “upset forged” from a single piece of high-strength steel give added strength and thickness for wear. A 48” load backrest extension is standard.

FRAME

The frame is a unitized construction, stress tested for durability. An integral step is provided for easy entry and exit. The truck has a two-piece floor plate that can be easily lifted out for service access. An easily removable counterweight top cover gives easy access to components. A stamped steel, gas spring-assisted hood allows easy changing of the battery. The battery compartment can be fitted with rollers.

ADDITIONAL FEATURES

Additional features on the ERC-VA include an overhead guard, 42” forks, non-suspension seat, seat belt and an operator sensing switch. An infinitely adjustable tilt steering column, rubber floor mat, and electric horn are also standard.

OPTIONS

Accutouch e-hydraulics Mini-levers
Foot Directional Control Pedal
Return to set tilt
Telescoping Steering Column with Tilt Memory
Rapid charge
Cold storage/freezer packages
Full suspension seats
Red (Hi-VIS) ELR non-cinch seat belt
Battery rollers
Overhead guard mounted headlights
Lowered overhead guard
Drive-in rack overhead guard
LED and Halogen work light packages
LED Dome/reading light
Brake and Tail light packages
10° forward tilt
Integral sideshifter
48 volt
Audible Alarm – Reverse Operation
Visible Alarm – Amber strobe
Various type drive tires
Type “EE” UL construction
Dual Rear View Mirrors
Panoramic Rear View Mirror
Fire Extinguisher
Accumulator

Truck performance may be affected by the condition of the vehicle, how it is equipped and the application. Consult your Yale® Industrial Truck Dealer if any of the information shown is critical to your application. Specifications are subject to change without notice.

This truck meets all design specifications of ANSI B56.1 Safety Standard for Powered Industrial Trucks at the time of manufacture. Classified by Underwriters' Laboratories, Inc. as to fire hazard only.

The Yale® products included in this document may be covered by US patent 6,959,936 and other patents pending.

Yale, **Yale**, Veracitor™ VX and Yale Global Hi Vis™ Mast are trademarks or registered trademarks of Yale Materials Handling Corporation in the United States and other countries.



Yale Materials Handling Corporation
P.O. Box 7367, Greenville, North Carolina 27835-7367

2382-1A 5/12

© 2012 Yale Materials Handling Corporation.  is a registered copyright of Yale Materials Handling Corporation. YALE and VERACITOR are registered trademarks of Yale Materials Handling Corporation. PREMIER is a trademark of Yale Materials Handling Corporation.

Manufactured in our own ISO 9001 and 14001 Registered Facilities